

Monte Carlo simulation of radioactivity γ -ray spectra recorded by a NaI detector in the marine environment

Research Team

C.T.Papadopoulos (P.I.), *Assoc.Professor, Physics Department, N.T.U.A, Greece*

R.Vlastou, *Assoc.Professor, Physics Department, N.T.U.A, Greece*

M.Kokkoris, *Lecturer, Physics Department, N.T.U.A, Greece*

I.Th.Ntziou (*Research Student*), *Physics Department, N.T.U.A, Greece*

C.Tsabaris (*Research Associate*), *Hellenic Centre for Marine Research, Greece*

Introduction

In the studies of radiological assessment, ^{137}Cs is the most important radioactive contaminant, produced from the atmospheric bomb tests, discharges from nuclear reprocessing plants and the Chernobyl reactor accident. The systems most commonly used for the in situ monitoring of γ -radiation in seawater, are based on NaI(Tl) detectors, which are characterized by high detection efficiency and low cost [1-3]. They have, however, the disadvantage of relatively poor energy resolution and high background mainly originating from the Compton effect during the detection process of the high energy γ -rays from the deexcitation of natural radionuclides, such as ^{40}K and ^{214}Bi [4]. This makes the systems incapable for precise peak identification of the various gamma ray contributions, especially for low level radioactivity studies and in the low energy region, where the 661keV γ -ray of ^{137}Cs , is situated in the spectra.

In an attempt to increase the confidence of the spectra analysis and produce more reliable results in the concentration of low level environmental radioactivity, Monte Carlo simulations with the GEANT4 code [5] were performed to produce the background spectra induced by the natural radionuclides in the marine environment. The simulated γ -ray spectra were compared with real data recorded in seawater by a NaI detector operational on oceanographic buoys, developed by the Hellenic Centre for Marine Research [6], for the in situ monitoring of radioactivity in the Aegean sea. The comparison between the measured spectrum and the simulated one, could control the operation of the submersible detection system, to increase the confidence of the spectra analysis and produce more reliable results in the concentration of low level environmental radioactivity.**Experimental calibration of the NaI spectrometer** The NaI detector system, developed by the Hellenic Centre for Marine Research [6], has been tested and calibrated in the NTUA Nuclear Physics laboratory, in a 5.5m^3 water tank (shown in Fig.1.), before its deployment in seawater. It was thus surrounded by one meter of water, which is adequate to imitate the real marine environment, due to the high attenuation of the γ -rays in the water.

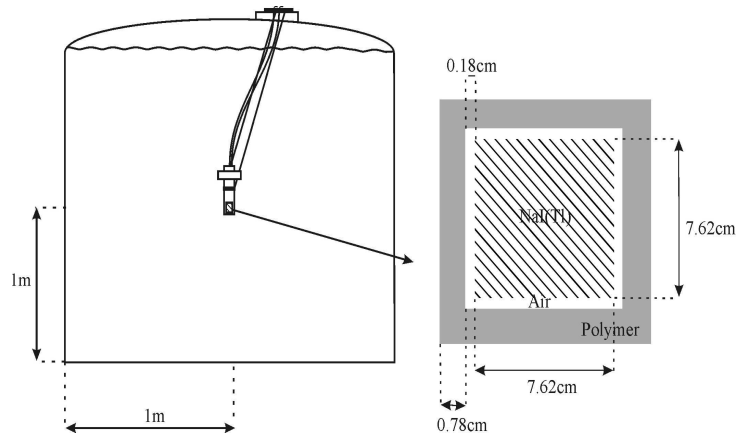
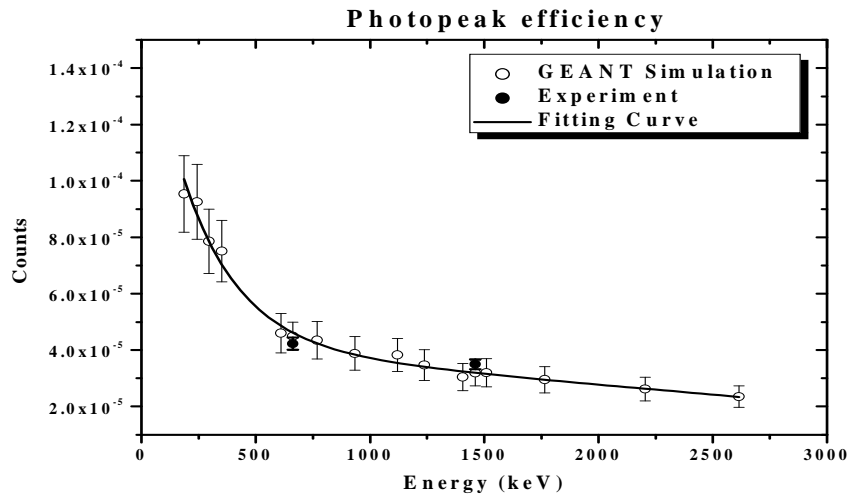

Figure 1. Layout of the water tank along with the NaI detector geometry, used both for the simulations and the experimental γ -ray data acquisition.

The γ -rays used to perform the energy calibration of the system were the 661keV of ^{137}Cs and the 1461keV of ^{40}K . 1995gr natural KCl and liquid ^{137}Cs were diluted in the tank water (together with 65% HNO_3 0.005N), resulting in $(3980 \pm 25) \text{ Bq/m}^3$ and $(6037 \pm 120) \text{ Bq/m}^3$ volumetric activity, respectively for ^{137}Cs and ^{40}K . Experimental spectra taken by the NaI spectrometer in the tank, with the above mentioned activities of ^{137}Cs and ^{40}K diluted in the water, were analyzed in order to extract the experimental values of the photopeak efficiency. The derived values are shown in Fig. 2, in comparison with the efficiency curve simulated by the GEANT4 code, which will be described in the next



section.

Figure

2. Photopeak efficiency curve of NaI detector in water.

After the calibration process, the detector system was deployed in the seawater of Pylos to acquire real gamma ray data in the marine environment. This spectrum is shown in Fig.3 along with the simulated one, as will be described later.

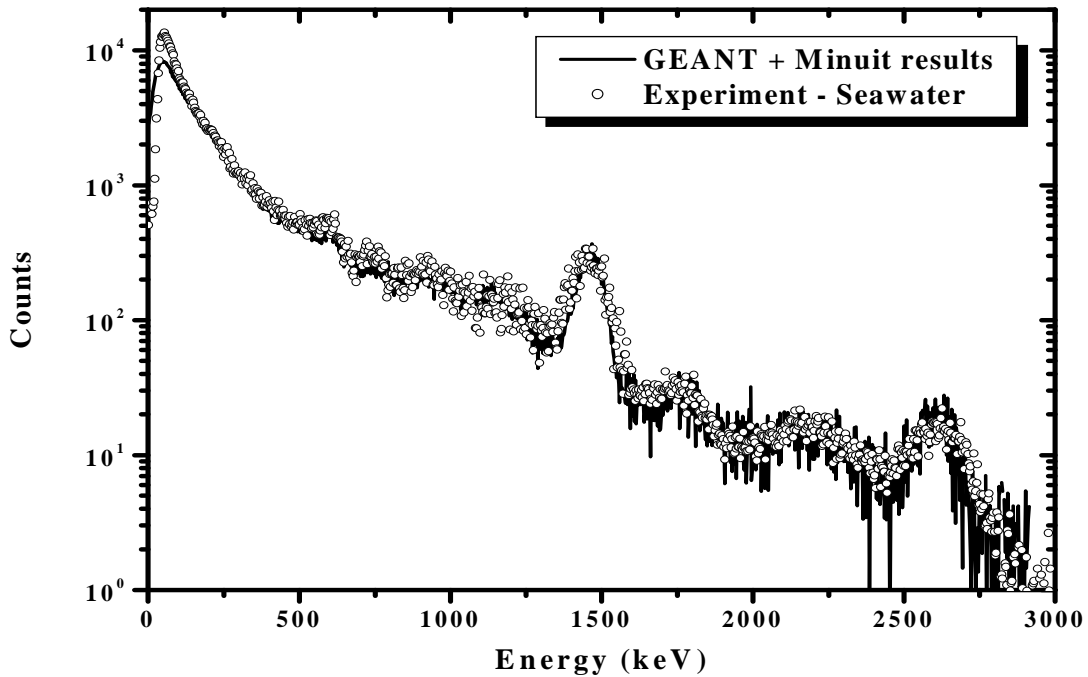

Figure 3. Experimental spectrum taken in the seawater of Pylos and simulated spectrum, assuming disequilibrium of natural radioactivity series.

The GEANT code simulations

The GEANT [5] code has been developed at CERN for high-energy physics experiments and simulates all relevant physical processes taking place in matter, along the passage of elementary particles from the source to the detector of any configuration. A detailed description of the geometry of the experimental set up (water tank and detector) and environment (water with radionuclides) with respect to their dimensions, materials and shapes, as well as the particle generator (radionuclides emitting photons), are required by the program to simulate and store the history of each photon from its generation in the water to full deposition of its energy in the detector system. In order to simulate the efficiency of the NaI detector in seawater, 16 strong γ -rays from the series of ^{238}U and ^{232}Th natural radioactivity were used to produce 16 spectra, one for each gamma ray, as well as for ^{137}Cs and ^{40}K . By integrating the photopeak counts and dividing by the total number of counts in each spectrum, the photopeak efficiency of the NaI spectrometer was deduced as a function of energy, as shown in Fig.2. The good agreement indicates that the simulated efficiency of the NaI spectrometer could be used over the full energy range for the concentration of any radionuclide emitting γ -rays.

Experimental and Simulated seawater Spectra In order to simulate the spectra of natural radioactivity in seawater, 67 gamma rays from the series of ^{238}U , ^{232}Th and ^{40}K were used. The contribution from the natural series of ^{235}U was considered to be negligible. Spectra were generated by the GEANT4 code for all the strong γ -rays (weighted by their relative intensity) of ^{234}Pa , ^{226}Ra , ^{222}Rn , ^{214}Pb , ^{214}Bi , ^{228}Ac ,

^{220}Rn , ^{212}Pb , ^{212}Bi , ^{208}Tl and ^{40}K . By varying the relative contribution of these spectra and getting the best fit to the real spectrum (taken with the NaI detector in the seawater of Pylos) with the MINUIT code by the χ^2 minimization technique, the relative abundance of ^{238}U and ^{232}Th series and ^{40}K in sea water was deduced. [7]. The simulated spectrum is presented in Fig.3 along with the experimental one and are found to be in very good agreement. The expected deficiency of radium and lead has been confirmed by the fitting procedure, verifying the disequilibrium of the natural radioactivity in seawater. Indeed, ^{226}Ra and lead salts are insoluble in water and precipitate down to the sediment surface, implying distortion of the secular equilibrium and lower concentration of their daughter radionuclides.

Good fit between real and simulated spectra could be achieved without any contribution from the artificial radionuclide ^{137}Cs . This implies low concentration of ^{137}Cs in the seawater, below the lower limit of detectability of the NaI system. This result is corroborated by laboratory measurements of the ^{137}Cs concentration in seawater from the same region of Pylos, by using a HPGe detector system, of 80% efficiency, appropriately calibrated. The concentration of ^{137}Cs was extracted from these measurements to lie between $2\text{-}3\text{Bq/m}^3$ [8], too low to be determined in situ by the NaI spectrometer. **Conclusions**

In the field of on line measurement of environmental radioactivity, the continuous control of the detector performance is of major importance. In the case of on line γ -ray spectra recorded in seawater by a NaI system, the high background, induced by the natural radioactive constituents of seawater, prevents the detection of low level anthropogenic radioactivity. Thus, the identification of the most important radioactive contaminant ^{137}Cs by the 661keV γ -ray, becomes extremely unreliable.

In order to control the operation of the detection system and produce more reliable results in the concentration of low level environmental radioactivity, Monte Carlo simulations with the GEANT4 code has been used in the present work, to generate the background spectrum induced by the natural radionuclides in seawater and compare it to a real spectrum collected by an underwater NaI detector system. The detector has been tested and calibrated in the laboratory in a water tank, before its deployment in the sea. The simulated γ -ray spectra were constructed by including 67 gamma rays from the natural series of ^{238}U , ^{232}Th and ^{40}K diluted in the seawater. Three spectra were produced due to ^{40}K and the series of ^{238}U and ^{232}Th . By varying the relative contribution of these spectra and getting the best fit to the real spectrum by the χ^2 minimization technique, the relative abundance of ^{238}U , ^{232}Th and ^{40}K in the seawater was deduced. The expected deficiency of radium and lead in seawater has been confirmed by the fitting procedure, verifying the disequilibrium of the natural radioactivity.

The simulated spectrum representing the natural radioactivity, could be used for comparison with the real spectrum to test the performance of the detection system and to monitor the fallout. It could also be used to improve the detectability of low-level radioactive pollutants, such as ^{137}Cs . In the present work, however, the simulated spectrum could easily fit the real data recorded by the detector without any contribution from ^{137}Cs . This implies low concentration of ^{137}Cs in the seawater, below the lower limit of detectability of the NaI system. This result is corroborated by laboratory measurements of the ^{137}Cs concentration in seawater from the same region, which was found to be very low, between $2\text{-}3\text{Bq/m}^3$.

References

1. Povinec, P.P., Osvath, I. and Baxter, M.S., Underwater Gamma-spectrometry with HPGe and NaI(Tl) Detectors. *Appl.Radiat.Isot.* 47, 1127-1133, 1996.
2. Wedekind, Ch., Schilling, . G., Gruttmuller, . M. and Becker, K., Gamma-radiation monitoring network at sea. *Appl.Radiat.Isot.* 50, 733-741, 1999.
3. Osvath, I. and Povinec, P.P. , Seabed γ -ray spectrometry : applications at IAEA-MEL. *J.Environ.Radioactivity* 53, 335-349, 2001.
4. Tsabaris, C., Vlachos, D.S.,Papadopoulos, C.T., Vlastou, R. and Kalfas, C.A., 2004. Application of an underwater γ -ray spectrometer for radioactivity measurements. *Mediterranean Marine Science (MS 194)*, in press, 2004.Tsabaris, C., Thanos, I. and Dakladas, Th., The development and application of an underwater γ -spectrometer in the marine environment. *Radioprotection Suppl.1*, in pres, 2004.
6. CERN, 1993. GEANT Detector Description and Simulation Tool, *CERN Program Library Office, CERN, Geneva*.
7. Vlastou, R, I.Th. Ntziou^a, M. Kokkoris, C.T. Papadopoulos and C. Tsabaris. Monte Carlo simulation of γ -ray spectra from natural radionuclides recorded by a NaI detector in the marine environment. *Applied Radiatiopn and Isotopes*,in press .
8. Delfanti, R. Tsabaris, C., Papucci, C., Kaberi, H., Lorenzelli, R., Zervakis, V., Tangherlini, M. and Georgopoulos, D., Re-distribution of ^{137}Cs Chernobyl signal in the Aegean Sea. *Proceedings of the International Conference on Isotopes in Environmental Studies-Aquatic Forum, Monaco, 2004*.